



"Making knowlege work for us"



SANITATION SERVICES IN INFORMAL SETTLEMENTS

Sewering Lessons From Western Cape



ACKNOWLEDGEMENTS

This lesson is compiled from the Water Research Commission (WRC) report No. TT 557/13: TIPS For Sewering Informal Settlements: Technology, Institutions, People and Services.

The report was written by Lina Taing, Neil Armitage, Nangolo Ashipala, and Andrew Spiegel.



ACRONYMS

| | | |
|-----------------|---|--|
| CoCT | - | City of Cape Town |
| DAG | - | Development Action Group |
| EPA | - | Environmental Protection Agency |
| FBS | - | Free Basic Services |
| HIUP | - | Hangberg In-situ Upgrade Project |
| NGO | - | Non- Governmental Organisation |
| O&M | - | Operation and Maintenance |
| PM | - | Project Managers |
| StatsSA | - | Statistics South Africa |
| STED | - | Septic Tank Effluent Drainage |
| STEP | - | Septic Tank Effluent Pumping |
| UN-DESA | - | United Nations Department of Economic and Social Affairs |
| WRC | - | Water Research Commission |
| WSISU | - | Water and Sanitation Informal Settlements Unit |
| W&SD | - | Water and Sanitation Department |
| WWTW | - | Wastewater Treatment Works |

TABLE OF CONTENTS

| | | |
|----|--|----|
| 1. | SIMPLIFIED SEWERAGE AND THE CONDOMINIAL APPROACH | 4 |
| 2. | Settled Sewerage | 8 |
| 3. | Vacuum Sewerage Systems | 13 |
| 5 | Conclusion | 19 |

BACKGROUND

According to the United Nations Department of Economic and Social Affairs (UN-DESA, 2010), about 58% (30.4 million) of South Africa's total population of 52 million live in urban centres. Statistics South Africa (StatsSA), approximates that of these, 13% (1.86 million) of households were in 'informal dwellings' or 'shacks' in 2010, with minimal access to basic services.

With the introduction of the Free Basic Services (FBS) policy in 2001, which focused on infrastructure delivery to meet the basic infrastructure needs of the country's urban and rural poor, municipalities were mandated to provide limited amounts of clean water, electricity, sanitation, drainage and solid waste removal services for free to all South Africans.

Although 'full-flush' toilets were deemed the most appropriate sanitation technology for dense urban settlements by national government and generally preferred by users, installing conventional (gravity) sewerage in informal settlements (settlements that are not part of the formal or conventional town planning) as part of the FBS policy is however not easy given various social and technological constraints.

Informal settlement residents often demand that local authorities upgrade services in the areas where they currently live because the settlements are close to existing formalised neighbourhoods, transport links, etc. Yet dwellings in informal settlements tend to be laid out in a manner that is not conducive for retrofitting drainage according to conventional engineering standards.

Further, even technologically sound concepts or technologies are bound to fail disastrously in its implementation if there is strong emphasis on how the technology can 'solve' sanitation problems, without considering the social aspects, i.e. the people who provide, use or manage such systems will likely determine if a project succeeds or fails.

Alternative approaches to providing sewerage to informal settlements (which have been developed and applied worldwide) need to be investigated in order to determine whether there are other means of providing these areas with low-cost wastewater collection systems.

Building on previous South African research into alternative sewerage, a study by the Water research Commission (WRC) has analysed the outcome of the utilisation and management of these alternative sewerage systems in three Western Cape cases, as follows:

- i. Simplified sewers and vacuum sewers in the two Cape Town informal settlements of Hangberg and Kosovo.
- ii. Settled sewers in the formal areas of Hermanus.

The three case studies endeavour to illustrate a variety of socio-political and risk factors that cause sanitation facilities and projects to succeed or fail, especially in informal settlements.

Purpose of the Lesson

This lesson aims to present the technological, institutional, social, and servicing lessons on the use of alternative sewerage systems in the Western Cape.

ALTERNATIVE SEWERAGE SYSTEMS

1 SIMPLIFIED SEWERAGE AND THE CONDOMINIAL APPROACH

Simplified sewerage and the condominial approach were conceived in the 1980s by a team of sanitary engineers led by Jose Carlos de Melo, who sought an innovative way to provide waterborne sanitation to Brazil's high-density peri-urban areas at a lower-cost than conventional methods. Simplified systems (as with conventional gravity sewerage) rely on gravity to transport wastewater. Simplified sewer specifications are based on the re-evaluation and subsequent relaxation of conventional gravity sewerage design standards, which many engineers had deemed to be excessively high in cost due to design standards that were more conservative than operationally required.

More recently, 'condominial systems' are referred to as both physical 'sewer systems' and 'participatory approaches' that involve neighbourhood units (or 'condominiums') in the project design process and the simplified sewer construction and management. It is important to distinguish the technology from the participatory process because:

- Not all simplified sewers are designed, constructed or managed using a condominial approach.
- Failing to distinguish between the technology and the process has created confusion for a number of professionals.

Internationally, simplified sewerage installations have had great success in Pakistan, Australia, India, the United States, Zambia, and throughout South America, particularly in Brazil.

The condominial approaches' potential for success was even more when implemented in conjunction with simplified sewer installations in Orangi, Pakistan and El Alto, Bolivia. In both instances, the service providers' consultation and communities' participation not only reduced labour costs as compared with conventional installations, but also created a sense of ownership for the simplified sewers, and as a result users were more likely to use and maintain them appropriately.

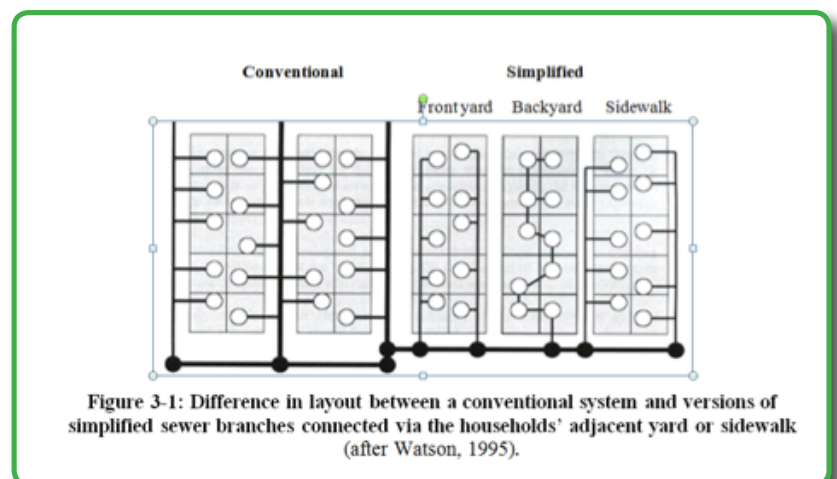

(For more information, please refer to the WRC report TT 557/13).

SIMPLIFIED SEWERS IN HANGBERG (HOUT BAY, CAPE TOWN)

Background



dwellings located beneath the 'sloot' (ditch) with views overlooking the harbour



a dwelling in neighbouring Dallas section

Nestled on the slopes of the Sentinel Mountain, Hangberg, a sprawling 3.7-hectare informal settlement with about 302 dwellings, overlooks the Hout Bay harbour. In 2001, the CoCT provided Hangberg residents with 37 tap-stands and 39 shared full-flush toilets. The toilets were supplied and drained by simplified sewers because conventional sewerage was unsuitable for the settlement's sandy and rocky soils. Gravity-driven sewers could be laid because the settlement has a steep slope (1:3 to 1:5). The shallow (now frequently exposed) water supply pipes and waste and stormwater sewers were meant as a 'temporary' measure because, at the time, the settlement was earmarked for an upgrade. Some residents – through their innovation, plumbing know-how and cooperation – subsequently improved their water and sewerage services by making private household connections without CoCT's assistance.



informal dwellings built behind a row house.

Sanitation Management and Technical Sewer Challenges

Hangberg's simplified sewer mains, often laid underneath dirt paths, comprise of 160 mm diameter pipes. However, the 160 mm pipes are incompatible with the 110 mm conventional sewer that it connects into. Blockages have since occurred where the two pipes join, with raw sewage seeping from a nearby manhole. Further, the responsibility for managing tap-stands and toilets has not been taken up by anyone, leading to loss of doors and toilet seats, taps and cisterns breaking and the sandy soils on which the toilet structures were placed have eroded as a result of stormwater run-off and the wind. Eventually, in a 2011 inspection of the settlement by CoCT officials, a municipal contractor and residents, all parties decided that all the shared toilets installed in the past decade would be replaced at the municipality's cost.

Dissatisfied with the municipally-provided facilities, some residents stopped using them altogether after they built or paid a skilled neighbour/contractor to connect their homes to the simplified pipe network. By 2006, over 40% of the residents had installed toilets in their homes while close to 80% had connected to the water supply network. It is significant to note that some residents have taken it upon themselves to 'upgrade' their services independent of subsidies from South Africa's Free Basic Services policy. By installing their own service, residents thus assumed responsibility for maintaining the household connection themselves.



Municipal and private sanitation facilities in Hangberg informal settlement. From top left clockwise:
 (a) a shared toilet without a door, (b) a toilet with an unstable structure due to an eroded base, (c) a bathroom in a resident's bungalow and (d) an unauthorised private connection to the exposed sewers.

The Hangberg residents' self-sufficient approach to providing one's own sanitation needs – financed and driven without any government subsidies or assistance – would generally be commended in international circles. The unauthorised connections have nevertheless affected the integrity of the water supply and sewer service for the shared toilets; for example, problems such as low water pressure are due to pipe network leaks caused by shoddy plumbing. In addition to leaks caused by poor jointing, there was also concern about where some residents were discharging their waste, as there is no wastewater sewer in the area. It is suspected that many of the households were draining their waste into stormwater outfalls.

An in-situ upgrade project was meant to improve service connections using municipal funding, thereby incrementally ensuring that all connections fit accepted engineering standards. Delays in the commencement of the upgrade project have, however, meant that Hangberg residents continue to install their own connections so that they have private facilities to use in their homes.

Lessons Learnt

- As of 2012, Hangberg residents and CoCT officials were seemingly satisfied with the simplified sewers in the settlement. Unlike with eThekweni simplified sewer installations, Hangberg residents had installed the branch sewers and household connections at their own cost without the assistance of the municipality. Residents installing their own services would usually be viewed as desirable for struggling municipalities; however, eThekweni's problematic connections in Briardale and CoCT officials' trouble with Hangberg's unauthorised connections have shown how the integrity of a sewer network can be compromised when connections are carried out by unskilled builders.
- Ideally, only skilled labourers should be used to construct sewer systems, whilst the issue of unauthorised connections in informal settlements needs to be addressed, particularly where sewers are shallow and easily accessed.
- During the process of installing the simplified sewers, there was a relationship break-down between the municipality and the NGO Social Facilitator, which highlights the need for the following in a partnership approach:
 - (a) Clear roles and responsibilities between the project team, particularly the service provider and any supporting organisations;
 - (b) Setting realistic expectations based on the constraints of the involved parties; and
 - (c) The need for Project Managers (PMs) of large infrastructure projects to possess project facilitation and negotiation skills. The Hangberg project management dilemma particularly illustrates the necessity of having able negotiators when planning informal settlement upgrade projects. This task is often outsourced by CoCT officials to supposed 'expert' supporting organisations with little consideration of how long the arrangement will last. Such arrangements have had disastrous consequences during negotiations between informal settlement residents and CoCT officials, as demonstrated by Development Action Group's withdrawal in the Hangberg project. Service providers need to consider whether it is pragmatic to employ independent organisations in the facilitation role given that project delays and prolonged time frames could preclude them from providing this critical service from a project's beginning to its end.

2 SETTLED SEWERAGE

Settled sewers were first designed in modern day Zambia in the 1960s. Like conventional and simplified sewerage, settled systems rely on gravity to convey effluent to a wastewater treatment works (WWTW) via a reticulation network. Furthermore, similar to simplified systems, costs can be relatively low for settled sewers because they require only shallow excavation depths, small-diameter pipework and simple inspection units in place of large manholes. However, they also require the insertion of interceptor tanks immediately downstream of toilets, baths and showers, but upstream of each connection point to the main sewer line – which must be periodically de-sludged. This allows for effluent with minimal amounts of total suspended solids to be conveyed to the treatment facility whilst the settleable matter is collected in the interceptor tank. Thus, settled systems are sometimes referred to as ‘solids-free sewerage’. Settled systems are recommended as a low-cost sewerage alternative for areas where housing densities have risen to a point where sewers have become necessary.

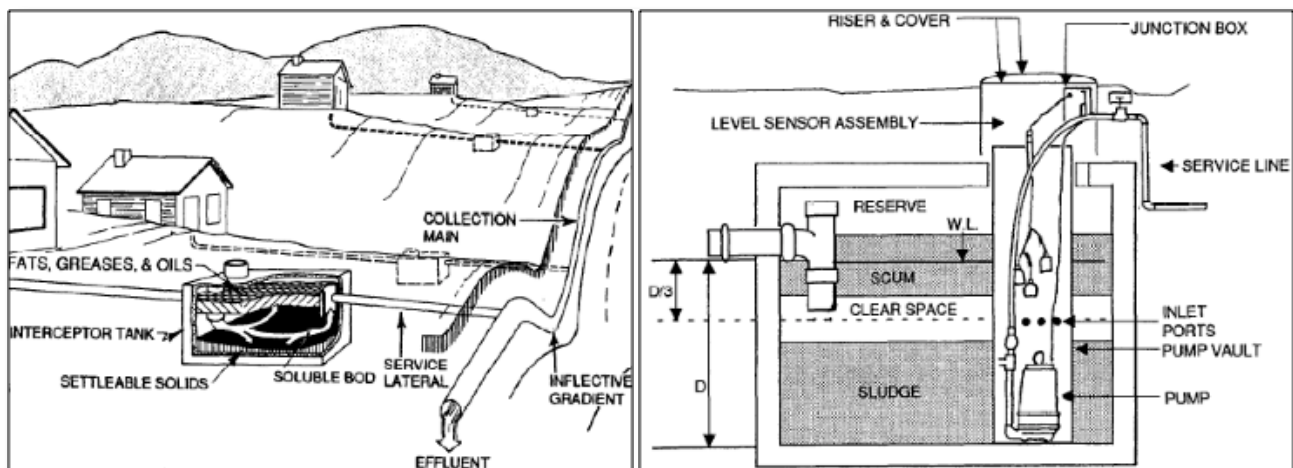

STED system (left) and a STEP system (right)

There are two variations of the system: Septic Tank Effluent Pumping (STEP) and Septic Tank Effluent Drainage (STED). Both systems settle solids in interceptor tanks, but the two systems transport effluent to the WWTW differently.

Settled sewerage is particularly useful in areas where water supply is limited or unreliable, with flat or undulating terrain and where deep excavations would be problematic due to underlying hard rock, unstable soils or high groundwater tables. Settled sewers are also well suited to remote areas where houses are far apart from each other allowing for effluent, free of large solids, to be conveyed over long distances in relatively small diameter pipes with minimal hydraulic losses.

Internationally, settled sewers have been built and operated in Zambia, the United States, Australia, Nigeria, South America and South Africa. Settled sewerage are used primarily in low- to medium-density peri-urban areas.

The attraction of settled sewers stems from the fact that they appear ‘robust’ and require minimal and non-specialised O&M. The communal aqua-privy systems and settled sewers in Zambia were still partially operational after nearly 40 years despite poor O&M.

Despite the various O&M problems experienced with the aqua-privy systems and settled sewers in Zambia, most were “immediately alleviated by emptying the tanks of sludge” and “could be restored to full effectiveness [if] adequate maintenance was carried out”. Furthermore operators of systems in the United States and South Africa report that settled sewers had “proven to be largely trouble-free with low maintenance requirements”, thus making the system seem all the more attractive to local authorities interested in finding an affordable and low-maintenance sewerage ‘solution’.

(For more details, please refer to the WRC report TT 557/13)

SETTLED SEWERS IN HERMANUS

Background

Hermanus has grown from a small seaside resort town into the economic and administrative hub of the Overberg District with a population of approximately 49,000 people. The town, which falls under the administration of the Overstrand Municipality, is spread along a 25 km stretch of coastline between the Bot River lagoon and the Klein River estuary. In 2008 the town was made up of 14,164 residential stands comprising approximately 13,726 permanent and 438 holiday homes and 650 commercial properties (Overstrand Municipality, 2009).

There are three sanitation systems in Hermanus: conventional sewerage, conservancy tanks and settled sewerage. Settled sewers, on the other hand, are mainly located in suburban areas. In 2010, 5,272 properties were serviced by settled sewerage in the Hermanus suburbs of Vermont, Voelklip, Onrus, Sandbaai, Santa Claire, Kitbroek, and Hemel n’ Aarde estate.

A settled system is suitable for the town’s conditions of flat slopes and shallow rock. It is also sensible since the town is a seasonal holiday town, and thus has “*widely varying flow volumes throughout the year*”.

The settled sewer network was initially installed because it was considered to be less expensive than a conventional system.

Breakdown of household sanitation types in Hermanus

| Sanitation system | Conventional sewerage | Conservancy tank | Settled sewerage | Total |
|-----------------------------|-----------------------|------------------|------------------|--------|
| Number of households served | 6,725 | 5,513 | 5,272 | 17,510 |
| Percentage of total | 38.4% | 31.5% | 30.1% | 100% |



The 63 mm outlet filter (left) that is installed in Hermanus' properties. The middle photo is of a filter on a new tank that was just commissioned and the photo on the right is of a settled tank that has been in operation for several years (Photos by Ashipala (2010) and Taing (2012)).

Dividing the O&M responsibilities and financial costs for settled systems between the property owner and Overstrand municipal officials is also a straightforward process as it is similar to previous sanitation arrangements when the owner was responsible for maintaining their conservancy or septic tanks and would contact the municipality to de-sludge them when necessary. A 5 kℓ tank is generally pumped every 4-5 years, and two municipal teams are responsible for emptying the tanks and maintaining the settled sewer collection mains extending up to the tank outlets, and both are experienced and familiar with the system.

Overall, settled sewers are a good system that is easy to construct and manage. The system reduces the immediate and long-term loading at the treatment facility, and can be designed with low water consumption fittings – thereby reducing water demand.

Challenges

For the first three months after the system was implemented on a wide-scale, the municipality had to constantly address a number of technical problems that caused sewage overflows. After the first three months, the settled sewer O&M teams generally had fewer problems than the conventional sewer teams, though this may however have more to do with settled systems having been introduced primarily in low-density areas with holiday homes (thus infrequently used).

Residents had been apprehensive about installing settled systems when the municipality first initiated the transition from the conservancy / septic tank system to a settled sewer network. The Overstrand municipal departments thus undertook an awareness campaign targeting households and local schools. Upon reflection, the high levels of acceptance by users and Overstrand officials alike are not surprising because there has been little change to the operation of the sanitation system. Residents – and businesses – call the municipality whenever their tanks must be de-sludged.

The main problem municipal officials have experienced with the settled sewerage system has concerned users directing stormwater to the collection mains, which has resulted in wastewater backing up from some properties' interceptor tanks. Illegal stormwater connections pose a greater risk for settled sewer systems than conventional sewerage as the small diameter sewers are not designed for stormwater inflow and groundwater infiltration and thus have less capacity than conventional systems.

Currently Overstrand officials are reluctant to use settled sewerage in Hermanus' informal settlement of Zwelihle because of the high risk of inert items being disposed in the system. If this were to occur, then: (a) biological processes occurring in the interceptor tanks might be interrupted, thus requiring the tanks to be emptied more frequently as waste would not efficiently degrade and (b) the objects may block tank outlets. O&M teams regularly unclog blockages caused by bricks, rags and sticks found in the informal settlement's conventional sewers.

Janitorial services for Zwelihle informal settlement's communal sanitation facilities (drained by conventional gravity sewers) were outsourced from mid-2009. Zwelihle, the only informal settlement in Hermanus, is home to 5,384 people. In the past, the communal toilets were handed over to residents to manage, but the municipality struggled with high maintenance costs associated with the constant blockages in toilets and sewer lines, and replacement costs when facilities broke-down. For the purposes of reducing such costs, officials engaged a number of local Zwelihle contractors to arrange a daytime janitorial service for the communal toilet blocks. Janitors are responsible for cleaning the facilities, collecting refuse 10 m around the toilet blocks, reporting broken or blocked toilets or basins on a daily basis to the municipal help desk, and distributing toilet paper.

In terms of facilities management, municipal officials had "more control" over the facility's condition, because janitors were available on-the-ground to assist with preventative maintenance or



A janitor shows how much toilet paper she distributes to users.

report problems immediately. In the past, officials had to “phone people directly” to learn of any problems. In the new system, janitors call-in O&M problems more or less on a daily basis to the municipal help desk personnel – who immediately log the complaints into the electronic work order system for municipal O&M teams to address.

Lessons Learnt

In summary, the advantages of Hermanus’ settled sewers over conventional systems are:

- Reduced municipal capital costs for public sewerage infrastructure,
- Reduced maintenance costs for residents when existing conservancy or septic tanks are converted, coupled with potential water savings for both the municipality and users.
- Overstrand officials’ extensive planning, adaptive management, troubleshooting and preventative maintenance have produced a well-designed and operated settled sewer system from a municipal perspective. They ensured good technical design, construction and management of the system by constantly turning previous mistakes into training sessions and lessons learnt, thereby using an adaptive approach to produce both technical settled sewer specifications and a step-by-step procedure for setting-up Hermanus’ effective settled sewer service.
- The Overstrand officials’ good design also extends to how they expected users to behave. Maintaining the same type of service for former septic or conservancy tank users (i.e. a private sanitation service that safely empties the tanks when full) and were thus familiar with essentially guarantees that there would be little resistance from users beyond the initial capital costs for the modification of the tanks.
- Overstrand officials also adapted sanitation services in the informal settlement Zwelihle according to user behaviour. Knowing that users were not going to take responsibility for O&M after several years of battling high rehabilitation costs in Zwelihle, a sanitation technology and service was chosen that would best achieve what residents and the Overstrand engineering department required.
- Overstrand officials also took responsibility for managing informal settlement sanitation facilities by employing a janitorial service as a preventative maintenance measure, just like eThekweni Municipality. The facilities have had municipally financed janitors available to distribute toilet paper and clean the facilities since mid-2009.

3 VACUUM SEWERAGE SYSTEMS

Vacuum sewers are often thought of as a 'new' technology, but their use in Europe and the United States dates back over 100 years (EPA, 1991). A vacuum sewer system was first developed for the city of Haarlem (The Netherlands) in 1866 and for Amsterdam in 1906. A commercial application was also developed and tested in a residential district of Stockholm by the Liljendhal Corporation of Sweden in 1959. Nevertheless, its development has lagged behind other wastewater collection technologies and it is commonly referred to in literature as a 'last resort' (PDH Engineer, undated). More recently, however, several companies have entered the world market for vacuum sewer systems (EPA, 1991). Within the last decade, vacuum sewers have even become viewed as a viable alternative to waterborne sewerage, with the lessons learnt from early systems resulting in improved design and operation guidelines (EPA, 1991). By 2004, there were over 1,000 vacuum sewerage systems operating around the world in the United States, Germany, Botswana, Namibia and Australia. The Water Corporation in Western Australia is considered the largest single owner of vacuum systems in the world with over 30 schemes operating under its jurisdiction.

Vacuum systems use differential air pressure to propel sewage through their own dedicated pipes to the main sewer network in an area. Unlike conventional, simplified or settled sewerage, vacuum systems do not rely entirely on gravity flows for wastewater conveyance and are thus less limited by topographical constraints. Vacuum sewers can be laid at considerably shallower gradients than those required for gravity-driven systems and can even transport sewage uphill for short lengths.

The large velocities at which wastewater travels through the pipes also reduce the risk of blockages. Whilst other sewerage technologies are generally more economic where the terrain can accommodate gravity systems, vacuum sewers may be more cost-effective where unstable soils or hard rock, flat terrain, high-water tables and/or restricted construction conditions impede the provision of gravity-driven sewerage. Under such conditions, the use of vacuum sewers may result in substantial reductions in excavation, material and treatment costs. The requirement to maintain air-tightness also makes vacuum sewers particularly useful in environmentally sensitive areas, as leaks are immediately detectable. Vacuum sewerage is, however, limited by the fact that it is a mechanised system that requires a reliable supply of electricity to the vacuum station. It should thus be generally limited to areas where a conventional gravity system would require numerous lift stations.

International experience

The use of vacuum sewers has increased substantially over the last 30 years, resulting in the introduction of waterborne sanitation in areas that would be difficult to service using gravity-dependent systems. Although early systems were fraught with numerous challenges, operating experience and advances in technology have allowed the development of more efficient and robust systems. On the other hand, the use of vacuum sewers in Southern Africa is potentially problematic because the lack of local experience can lead to poor construction and inadequate O&M. This has been substantiated by three installations in Sub-Saharan Africa, namely Shoshong in Botswana, Gibeon in Namibia and Kosovo, an informal settlement in Cape Town, South Africa.

VACUUM SEWERS IN KOSOVO (PHILIPPI, CAPE TOWN)

The Kosovo vacuum system is the South Africa's first vacuum system. The informal settlement's geotechnical, physical and social constraints had precluded the installation of a conventional sewer thereby necessitating the application of an alternative technology if the area were to be sewered. In fact, the vacuum system was seen to be an ideal technology for many of Cape Town's dense informal settlements because it requires shallower trenching, fewer pump stations and less residential relocation than gravity systems.

The vacuum sewer in Kosovo was installed as part of a visionary 'integrated' settlement-wide basic service upgrade project planned in collaboration with Kosovo community leaders.

Each toilet cluster has between six and fourteen toilets, and is drained by a 110 mm diameter gravity sewer conveying wastewater to an adjacent 40-litre collection chamber sump. The collection chambers' 63 mm diameter interface valves connect to vacuum sewer mains which range from 90 mm to 250 mm in diameter. Pre-cast concrete rings with lockable lids were placed over the collection chamber / interface valve assemblies as a security feature to help protect them from damage.

The CoCT Water and Sanitation Department (W&SD) has however since struggled with the O&M of the system since it was handed over from the city's then Housing Department (Department of Human Settlements) in 2009. The W&SD adopted a trial and error approach, but this has proven to be ineffective because the users' behaviours and operators' reactive practices that cause the system to malfunction were not redressed. Kosovo's unresolved vacuum sewer problem has become yet another example of how a seemingly technologically sound concept has failed disastrously once implemented because the people involved neither supported the processes in place, nor each other. If the system were to be rehabilitated, a number of institutional, technical and management adaptations to the current project planning, design and management processes would need to be addressed. Such process adaptations need to centre on CoCT repairing the system and employing residents as caretakers to help manage Kosovo's public facilities; however, CoCT has since elected not to rehabilitate the system and to instead replace the toilets connected to the dysfunctional system with non-sewered alternatives.



Open stormwater channel and drain



Communal toilets drained by vacuum sewer system



Location of Kosovo vacuum sewer system toilet clusters (CoCT, 2010b)

Challenges and Constraints

Since inception, the system has been hampered by users' (Kosovo residents') and service provider's (CoCT's) poor management. Residents continually complained about how the system was of inferior quality and as a result got blocked very easily. For example, sewage overflows regularly emanated from the toilets and drained directly below the washbasins that had been installed at the communal toilets. In some cases, the overflowing sewage flooded neighbouring shacks.

Nevertheless, blockages continued rendering most of the toilets completely unusable. Residents' disposal of items such as cutlery and bricks into the system sometimes caused flooding when interface valve diaphragms, pierced by sharp objects, remained closed, and bulky items blocked sumps. Wastewater thus regularly inundated the collection chambers and seeped through the covering concrete rings into the local environment. Sensor controllers also malfunctioned due to fats and dirt clogging pilot tubes, or were rendered completely useless from waterlogging; and the vacuum pumps were overworked due to air leakages in the vacuum line.

Residents have subsequently permanently locked the majority of the toilet blocks in order to prevent anyone from using them. CoCT officials have also found the water supply pipes to some of the toilets blocks have been cut, and a set of toilets destroyed, presumably as a sign of the residents' discontent with the system.

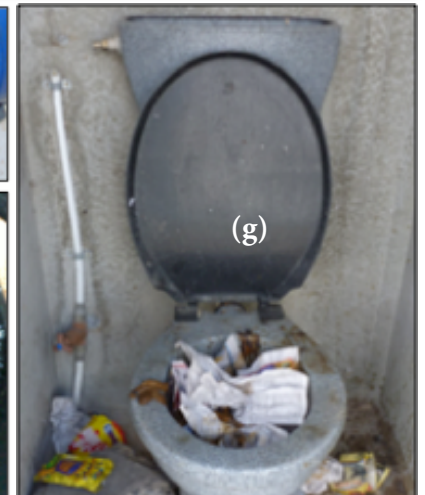
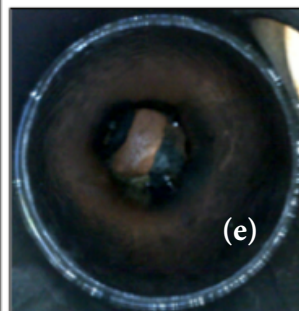

Photos of Kosovo's vacuum system and connected toilets. From the top: (a) raw sewage overflow from washbasin drain in June 2009, (b) attempts by residents to prevent spillage by covering drains with wooden boards in June 2009, (c) a used but disconnected toilet in November 2010, (d) a spoon piercing an interface valve diaphragm, (e) a brick in a sump, (f) a submerged collection chamber in a flooded concrete ring in June 2010 and (g) destroyed toilets in July 2010

After the vacuum system first failed, the R17 million technology's collection chambers primarily functioned as a series of 40-litre conservancy tanks. In 2009/10, 26 tanks were regularly desludged thrice weekly at an annual cost of around R500, 000. Calculated in terms of litres of waste collected and transported for treatment, the conservancy tank toilets have cost the CoCT's Water and Sanitation Informal Settlements Unit (WSISU) 18 times more than Kosovo's container toilets to service, and four times more than 'expensive' chemical toilets (see table below). Residents have come to view the malfunctioning vacuum system as an inferior technology to conventional systems (Beauclair, 2010) and by 2011 were demanding alternative connections to gravity sewers or the system's complete replacement with the – generally detested – container toilets, which at least 'safely' contain wastewater.

Approximate 2009-10 servicing costs for Kosovo's sanitation provision (Jooste, 2010).

| | Costs (1/7/2009 to 30/6/2010) | Number of units serviced | Number of servicing per week | Total litres of waste disposed | Cost per litres of waste disposed |
|--|-------------------------------------|-----------------------------|------------------------------------|-----------------------------------|--------------------------------------|
| Failed vacuum system collection chambers as conservancy tanks | R500,000 | 26 collection chambers | 3 | 162,240 | R3.08 |
| Container toilets | R1,391,015 | 256 toilets | 6 | 7,987,200 | R0.17 |
| Chemical toilets | R1,572,160 | 130 toilets | 3 | 2,028,000 | R0.78 |

All municipal officials familiar with Kosovo's vacuum sewer, including the project leadership, now acknowledge that regular blockages of the system by foreign objects and the municipality's lack of knowledge about how to manage vacuum systems suggest that it was an inappropriate technology for informal settlements as implemented. Further, Kosovo's vacuum system was bound to fail due to a number of institutional, residential and technical constraints that have paralysed effective municipal management. CoCT's responsibilities have been compromised by inter-departmental conflict and a lack of capacity in the municipality. High staff turnover, municipal restructuring and a lack of conflict resolution skills have resulted in inconsistent lines of project accountability that have made it difficult to hold any one person or department accountable for the system's failures or take responsibility for resolving the problems.

Notably, problems with Kosovo's vacuum sewer still persisted after three years in part because no one department or official has accepted responsibility for its management and rehabilitation, as the project's management often changed because of inter-departmental handovers and staff turnover. This has left the project with no champion to lead and support the initiative, which is key for its success.

Upon reflection, the above grievances all point to the entrenched silo management in CoCT planning and operation that has restricted inter-departmental cooperation and coordination at 'the city'. In CoCT governance, personnel are assigned specific job functions based on the focus of their departments' mandate. In this capacity, each official has a specific role (e.g. strategic planner, project manager or maintenance personnel) in the decentralised government. Yet, such narrow interpretations of responsibilities has had practical implications for O&M officials supporting municipal services because they rarely are involved in project planning, but would nevertheless be expected to cope with consequences of decisions in which they took no part.

The lack of municipal experience to manage vacuum systems, departmental tension between W&SD O&M teams and the lack of capacity to ensure new technologies reliably operate are further reasons why the vacuum system was an inappropriate technology choice for CoCT as a service provider.

Post failure, many officials and residents believe the vacuum system is an inappropriate technology for informal settlements because the system is too “sensitive” to conditions that prevail in such places. There is often utilisation of inappropriate personal cleansing materials in the vacuum system and solid waste is also indiscriminately disposed into the system. The vacuum system may be suitable for affluent areas that enjoy good solid waste disposal services and regularly use soft, biodegradable anal cleansers such as toilet paper, which many informal settlement residents cannot afford or refuse to purchase. Although some have even recommended that the vacuum system should be replaced with a conventional gravity sewer, any sewerage system is susceptible to blockage by bulky objects and by the build-up of grease and fats. What distinguishes a vacuum system in this regard is that blockages tend to occur locally at collection chambers and result in the discharge of sewage on site, whereas blockages in gravity systems tend to occur further downstream – away from the users. Thus, whilst the downstream users may suffer the consequences of upstream users’ behaviour, the blockage is someone else’s problem and not that of the perpetrators.

Lessons learnt

- In retrospect, it is evident that Kosovo’s vacuum system was bound to fail as implemented because neither the municipality nor the users were adequately prepared for the technological and social challenges of managing the system. Without an enabling environment to effectively plan and manage the new technology, coupled with inconsistent project leadership that subsequently left no one immediately accountable for the infrastructure, it is little wonder that CoCT officials have struggled to manage and rehabilitate the now discredited vacuum system.
- Moreover, residential leaders have not eased the situation as their contestations over the project’s limited employment opportunities caused a number of unnecessary delays to the servicing of one of the city’s densely populated informal settlements. This suggests that service providers should allow extensive periods for monitoring, evaluating and troubleshooting problems when implementing unfamiliar technologies. The Kosovo experience – as with Hangberg – indicates that CoCT, as the WSA responsible for service delivery, needs to adopt new policies and practices for the provision of sewerage in informal settlements.
- If vacuum systems are to be implemented in informal settlements in the future, service providers should critically assess how to control usage of the vacuum system. If a janitorial service and toilet paper cannot be provided, there will always be a high likelihood of rubbish being introduced into the system which could damage the interface valves and/or their operation. Under these circumstances, service providers should consider installing interceptor tanks between the toilets and collection chamber – in other words, creating a hybrid between settled sewerage and vacuum sewerage. Alternatively, the toilets can be installed over the interceptor tanks similar to an aqua privy system, with the tank outlets draining directly to the collection chambers. If such an approach is undertaken, then the service providers would also need to consider how often they would need to empty the interceptor tanks to ensure the vacuum system continues to operate optimally.



Evidence of greywater, food waste and solid waste disposal in Kosovo toilets connected to the vacuum sewer (Photos by Taing, 2010, 2011).

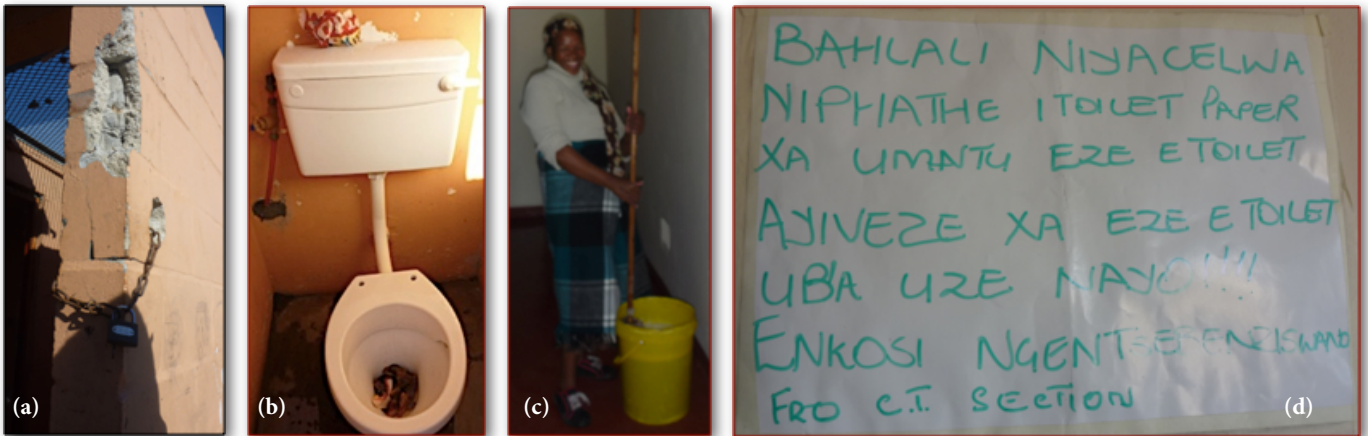

from left to right: (a) evidence of infrastructural damage from a break-in at TR Section's ablution facility, (b) a toilet in TR Section where newspaper was used as an anal cleanser, (c) a janitor at the CT facility, and (d) a sign posted at the facility's entrance entreating users (in isiXhosa) to use toilet paper.

- At the time of undertaking the study, CoCT officials had decided to decommission Kosovo's vacuum system and are assessing a non-sewered technology to replace the dysfunctional toilets. If the vacuum system is to be saved, the system would need to be rehabilitated, and some officials have advocated contracting a service provider for a year to operate and maintain it whilst the municipality builds its O&M capacity. Improved social management of sanitation assets in a service-driven informal settlement environment will also require janitorial services, and in Kosovo this has been recommended as part of a system rehabilitation programme that requires a holistic O&M strategy. Regardless of the technology, the CoCT Executive Management – not residential users – should provide janitorial services for all shared facilities. It is clear that the indisputable assignment of various O&M responsibilities is necessary to enable municipal officials and residents to hold each other accountable for the vacuum system's functioning and failures.

4 CONCLUSION

The case studies covered in this lesson endeavour to illustrate a variety of socio-political and behavioural risk factors that cause sanitation facilities and projects to succeed or fail, especially in informal settlements.

The lesson also shows that the ability of sewers to function as designed is closely related to how sanitation technologies are planned, managed and used. It attempts to show that failure of communal toilet facilities is very likely linked to users' expectations that sanitation 'services' should be provided for shared facilities, which is contrary to officials' explicit aims to provide only facilities that are managed by their users.

Compiled by:

Juliet Mwale

Edited by:

Dr. Valerie Naidoo and Juliet Mwale



The WIN-SA lesson series aims to capture the innovative work of people tackling real service delivery challenges. It also aims to stimulate learning and sharing around these challenges to support creative solutions. To achieve this, the lessons series is supported by ancillary learning opportunities facilitated by WIN-SA to strengthen people-to-people learning.

To find out more about these and other WIN-SA services go to the WIN-SA portal at www.win-sa.org.za or contact the Network directly.

This document hopes to encourage ongoing discussion, debate and lesson sharing. To comment, make additions or give further input, please visit www.win-sa.org.za or send an email to info@win-sa.org.za.

Our mission is to ensure the body of knowledge in the sector is well managed, readily accessible and applied, leading to improved decision-making and performance, especially of local government.

Address: 491 18th Avenue, Rietfontein, Pretoria

Postal Address: Private Bag X03, Gezina, 0031

Tel: (012) 330 0340 Fax: (012) 331 2565

E-mail: info@win-sa.org.za

Website: www.win-sa.org.za

